

**Modular Cooking Range Line
 thermaline 90 - 4 Zone Electric Solid
 Top on Oven, 1 Side, Ecotop with
 Backsplash, H=700**

ITEM # _____

MODEL # _____

NAME # _____

SIS # _____

AIA # _____



589653 (MCLMEBJ8AO) Electric Solid Top, 4 zones, ecoTop coating, one-side operated with backsplash, on Oven

Short Form Specification

Item No. _____

Unit constructed according to DIN 18860_2 with 20 mm drop nose top and 70 mm recessed plinth. Internal frame for heavy duty sturdiness in stainless steel. 2 mm top in 1.4301 (AISI 304). Flat surface construction, easily cleanable. THERMODUL connection system enables seamless worktop when units are connected and avoids soil penetrating. ECOTOP model with a 20 mm thick steel cooking surface with heat retaining coating. 4 independently controlled heating zones with 2 electronic sensors per zone for temperature surface control and 8 power levels. Rapid plate heat up, continuously ready to use. Electric static oven base with 40 mm thick oven door and ribbed enamelled steel base plate. Constructed according to 1.4301 (AISI 304). Oven chamber with 2 levels of runners for 2/1 GN shelves to enable simultaneous and faster cooking. Heavy duty thermostat with temperature range up to 300°C, electronic sensor for precise temperature control and manual humidity control in the cooking chamber. Upper heating element can also be used for grilling, with or without ventilating mode. Overheat protection switches off the supply in case of overheating. Standby function saves energy and quickly recovers maximum power. Metal knobs and oven handles ergonomically designed with embedded hygienic silicon "soft" grip enable easier handling and cleaning. IPX5 water resistance certification.

Main Features

- 4 heating zones independently controlled.
- Rapid heat up of the plate and continuously ready for use.
- Overheat protection: the temperature sensor switches off the supply in case of overheating.
- Pans can easily be moved from one area to another without lifting.
- Wide rounded cleaning zone around the plates for easier cleaning.
- All major components may be easily accessed from the front.
- THERMODUL connection system creates a seamless work top when units are connected to each other thus avoiding soil penetrating vital components and facilitating the removal of units in case of replacement or service.
- Metal knobs with embedded hygienic "soft-touch" grip for easier handling and cleaning. The special design of the controls prevents infiltration of liquids or soil into vital components.
- Cooking plate and base joint profile guarantee against soil infiltration.
- Two electronic sensors per zone to control surface temperature and to protect cooking plate from overheating.
- 8 power levels.
- Large visible digital display manufactured in tempered glass to resist heat and chemicals, showing temperatures or power settings. The display also shows on/off status of the appliance and on/off status of the heating elements.
- 40 mm thick oven door for heat insulation.
- Handles are ergonomically designed with silicon "soft" grip for easy handling and cleaning.
- Oven chamber to have 2 levels of runners to accommodate 2/1 GN trays and ribbed enamelled steel base plate.
- The upper heating element of the oven can also be used for grilling.
- Manual control of humidity in cooking chamber.
- Electronic sensor for precise temperature control.
- Unit constructed according to DIN 18860_2 with 70 mm recessed plinth.
- Oven temperature up to 300 °C
- ECOTOP model has a 20 mm thick steel DIN 1.7335 nickel coated cooking surface.

Construction

- 2 mm top in 1.4301 (AISI 304).
- Flat surface construction with minimal hidden areas to easily clean all surfaces
- Unit constructed according to DIN 18860_2 with 20 mm drop nose top.
- Unit constructed according to DIN 18860_2 with 20 mm drop nose top and 70 mm recessed plinth.
- IPX5 water resistance certification.
- Internal frame for heavy duty sturdiness in stainless steel.

APPROVAL: _____



Sustainability

- Standby function for energy saving and fast recovery of maximum power.

Included Accessories

- 1 of Grid, chromium plated, for ovens PNC 910652
2/1 GN

Optional Accessories

- Baking sheet 2/1 GN for ovens PNC 910651
- Fire clay plate 2/1 GN for ovens PNC 910656
- Connecting rail kit for appliances with backsplash, 900mm PNC 912499
- Portioning shelf, 1000mm width PNC 912528
- Stainless steel front kicking strip, 1000mm width PNC 912636
- Stainless steel side kicking strips left and right, against the wall, 900mm width PNC 912660
- Stainless steel side kicking strip left and right, back-to-back, 1810mm width PNC 912663
- Stainless steel plinth, against wall, 1000mm width PNC 912941
- Stainless steel plinth, freestanding, 1000mm width PNC 912960
- Connecting rail kit for appliances with backsplash: modular 90 (on the left) to ProThermetic tilting (on the right), ProThermetic stationary (on the left) to ProThermetic tilting (on the right) PNC 912981
- Connecting rail kit for appliances with backsplash: modular 90 (on the right) to ProThermetic tilting (on the left), ProThermetic stationary (on the right) to ProThermetic tilting (on the left) PNC 912982
- Back panel, 1000x700mm, for units with backsplash PNC 913015
- Stainless steel panel, 900x700mm, against wall, left side PNC 913101
- Stainless steel panel, 900x700mm, against wall, right side PNC 913105
- Endrail kit, flush-fitting, with backsplash, left PNC 913117
- Endrail kit, flush-fitting, with backsplash, right PNC 913118
- Endrail kit (12.5mm) for thermaline 90 units with backsplash, left PNC 913208
- Endrail kit (12.5mm) for thermaline 90 units with backsplash, right PNC 913209
- Insert profile d=900 PNC 913232
- Energy optimizer kit 40A - factory fitted PNC 913248
- Side reinforced panel only in combination with side shelf, for against the wall installations, left PNC 913267
- Side reinforced panel only in combination with side shelf, for against the wall installations, right PNC 913269
- Filter W=1000mm PNC 913666

- Stainless steel dividing panel, 900x700mm, (it should only be used between Electrolux Professional thermaline Modular 90 and thermaline C90) PNC 913672
- Stainless steel side panel, 900x700mm, flush-fitting (it should only be used against the wall, against a niche and in between Electrolux Professional thermaline and ProThermetic appliances and external appliances - provided that these have at least the same dimensions) PNC 913688

Front

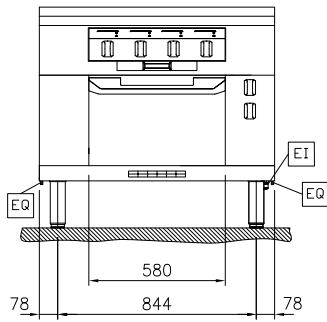

Side

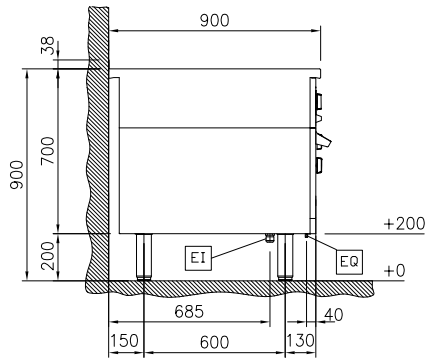

EI = Electrical inlet (power)
EQ = Equipotential screw

Top

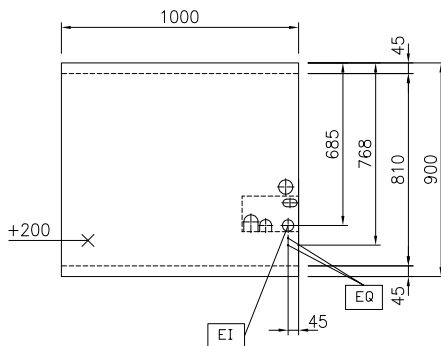

Electric

Supply voltage: 400 V/3N ph/50/60 Hz
Electrical power, max: 21.3 kW

Key Information:

Working Temperature MIN: 100 °C
Working Temperature MAX: 450 °C
External dimensions, Width: 1000 mm
External dimensions, Depth: 900 mm
External dimensions, Height: 700 mm
Net weight: 258 kg
Configuration: On Oven; One-Side Operated
Front Plates Power: 4 - 4 kW
Back Plates Power: 4 - 4 kW
Solid top usable surface (width): 820 mm
Solid top usable surface (depth): 720 mm

Sustainability

Current consumption: 40.3 Amps